

# INSTRUCTION MANUAL

## QHP-T3 SERIES TAPE CUTTER

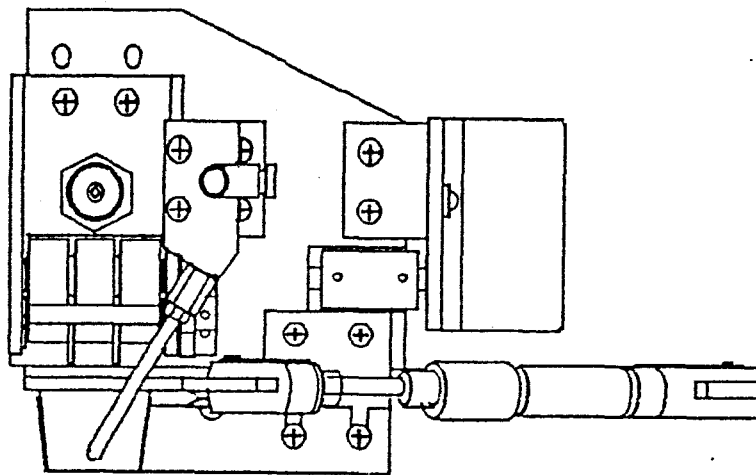

For Models QHP-778L, 778 & 772

## CONTENTS

Page

(1) List of Types of Tape Cutters (QHP-T3 Series) for Sealing Machines .....	1
(2) Replacement of L-shaped Nozzle (T3-8L QHP-778/772) ..	2
1: Removal of old part .....	2
2: Mounting of L-shaped part .....	3
(3) Connecting of Controller (T3-88 QHP-778/778L).....	4
(4) Connecting of Controller (T3-82 QHP-772) .....	5
(5) Mounting of Cutter (T3-0) .....	6
(6) Connecting of Air Tube and Connector .....	6
(7) How to operate the Tape Cutter .....	7
1: Operation Panel .....	7
2: Operation .....	8
Parts List .....	



(1) List of Models of Tape Cutters (QHP-T3 Series)

Model	QHP-778L	QHP-778	QHP-772
Tape Cutter	T3-778L	T3-778	T3-772

Breakdown

Cutter	1 Set	T3-0	←	←
Controller	1 Set	T3-8	←	←
Connecting Cord	1 Set	T3-88	←	T3-82
L-shape Nozzle Unit	1 Set	.....	T3-8L	←

- ☆ L Nozzle : L shape 20mm
- ☆ Controller : Fitted with air tube
- ☆ L shape nozzle unit : Semi-assembled
- ☆ tape guide : 20mm

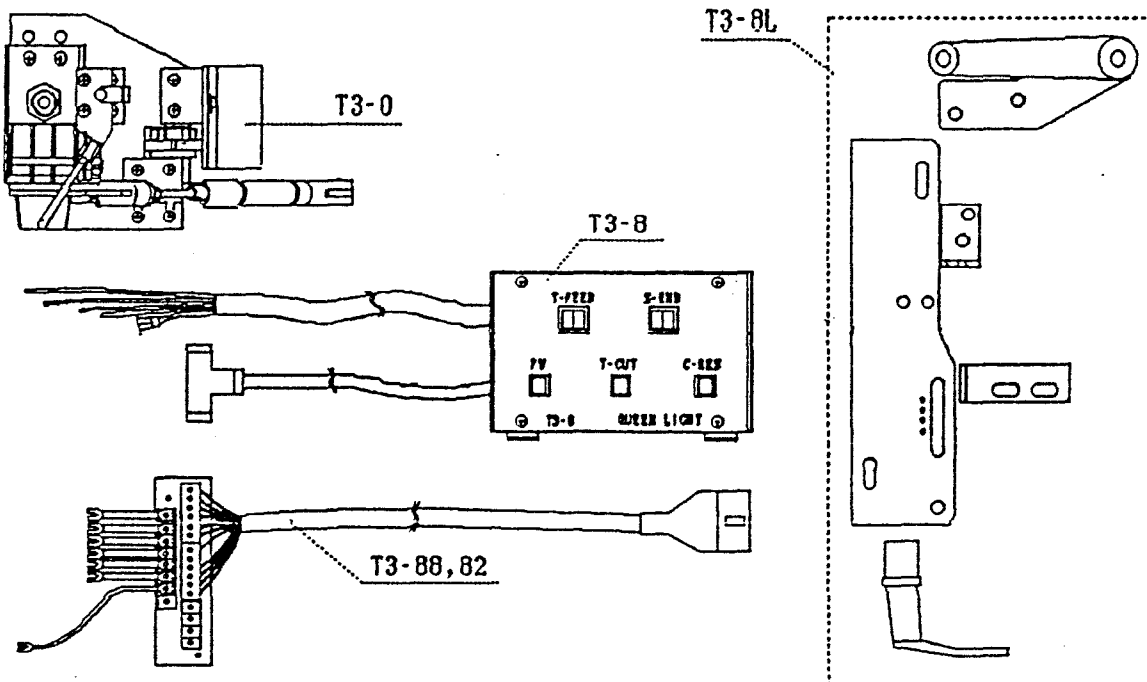

(2) Replacement of L shape nozzle (T3-8L QHP-778/772)

☆ Cut off the heater switch and confirm that the temperature of the heater and heater mounting part have cooled down followed with switching off of power and stopping air from the compressor.

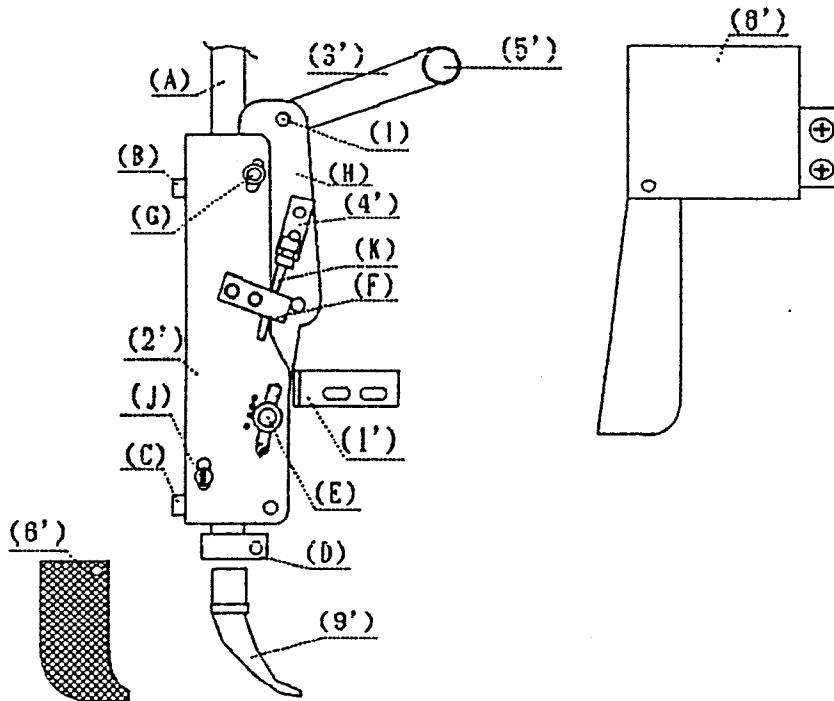

1: Removal of old part

(Screws and washers (A) - (K) are used at time of mounting of the L shape part.)

- 1) head cover (8') [2 set screws]
- 2) Nozzle cover (6') [2 set screws]
- 3) Nozzle (9') [Loosen screw of nozzle fastening piece (D)]
- 4) Vertical adjust screw bracket (F) [Provided with adjust screw (K)]
- 5) Adjust screw base (4')  
Stopper L (1')
- 6) Heater proper (A) [Set screws (C) (B)]
- 7) Heater retainer base (2') [Set screws (E) (G)]
- 8) Heater lift lever (3') [Loosen lever pin (5') and set screw (1), and pull out the lever pin (5') and (1)]

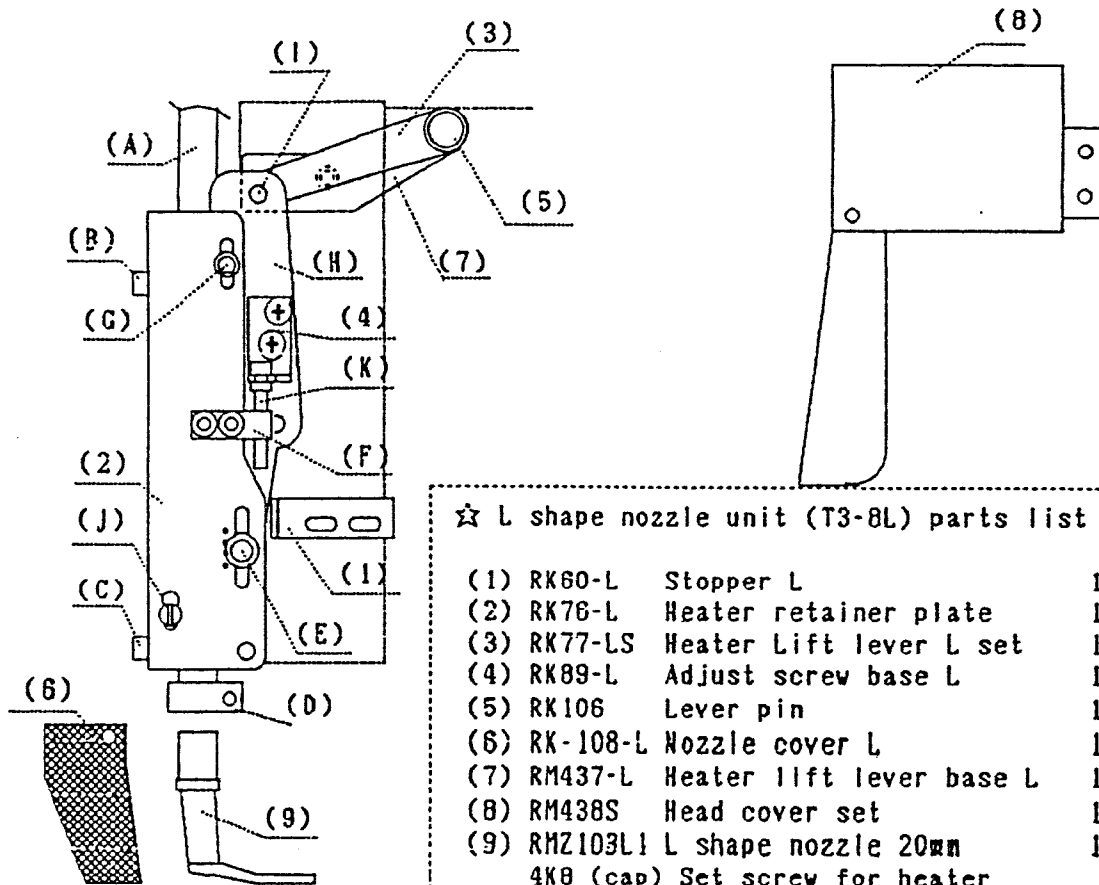

☆ L shape nozzle unit (T3-8L) parts list

(1) RK60-L	Stopper L	1
(2) RK76-L	Heater retainer plate	1
(3) RK77-LS	Heater Lift lever L set	1
(4) RK89-L	Adjust screw base L	1
(5) RK106	Lever pin	1
(6) RK-108-L	Nozzle cover L	1
(7) RM437-L	Heater lift lever base L	1
(8) RM438S	Head cover set	1
(9) RMZ103L1	L shape nozzle 20mm	1
	4K8 (cap) Set screw for heater	
	lift lever base	2
	4T8 (truss) Set screw for	
	adjust screw base L	2

2: Mounting of L shape parts

- 1) Heater lift lever base (7) [Fitting of 2 set screws (4K8) and (3), (5) finished]
- 2) Lever pin (I) [Insert into the heater lift lever L (3) from the pin hole of the heater mounting base (H) and tighten the set screw (3)]
- 3) Stopper L (1) [2 set screws]
- 4) Heater retainer base L (2) [Set screws (G), (E)]
- 5) Adjust screw base L (4) [2 set screws]
- 6) Vertical adjust screw bracket (F) [Provided with adjust screw and 2 set screws]
- 7) Heater proper (A) [Set screws (B), (C)]
- 8) Nozzle (9) [Height adjust: set screws (G), (E) + adjust screw (K)]  
[Forward-backward adjust: set screws (B), (C) + adjust screw (J)]  
[Left-right adjust: stopper L (1)]
- 9) Nozzle cover (6) [2 set screws]
- 10) Head cover (8) [2 set screws]

(3) Connecting of controller (T3-88 QHP-778/778L)

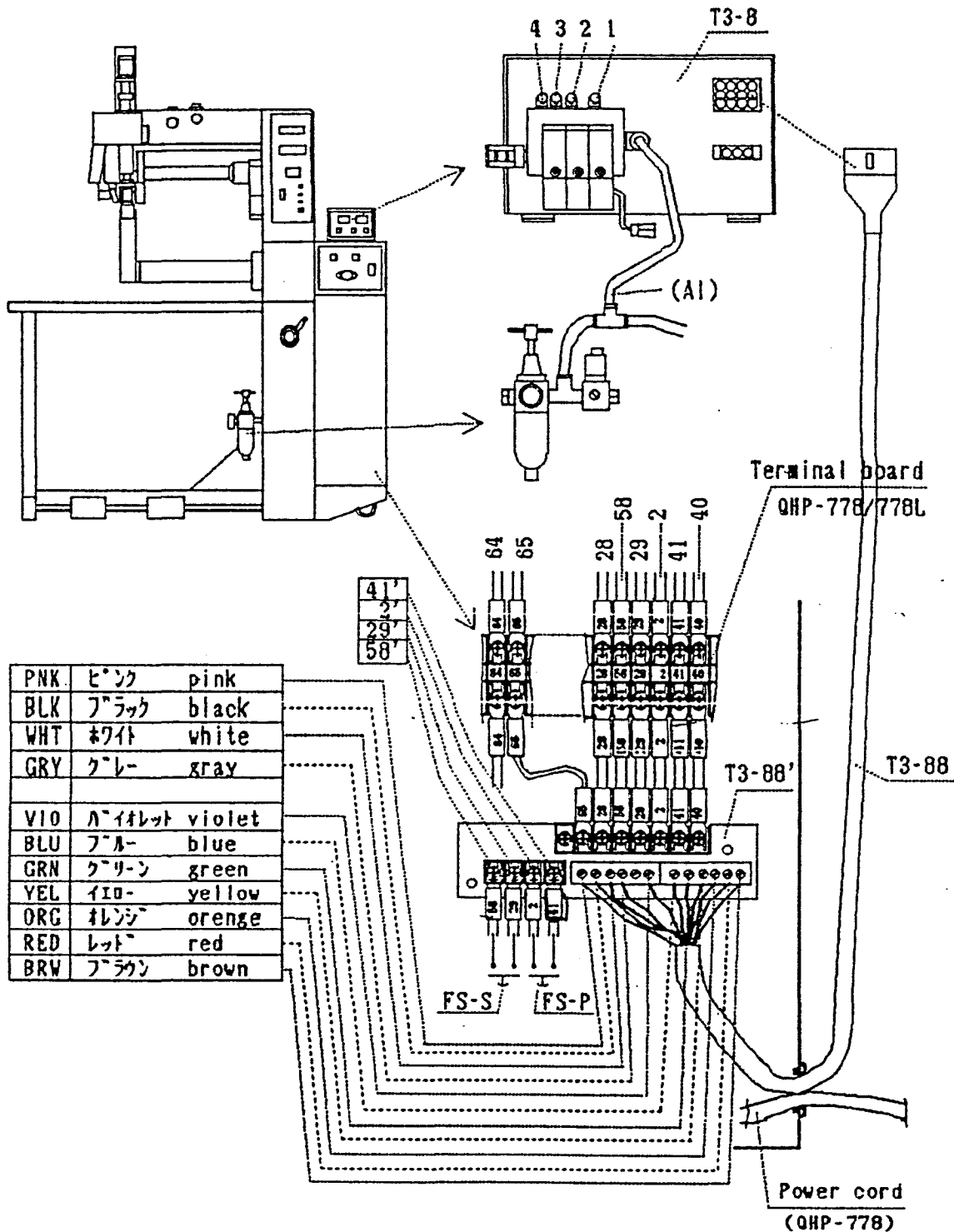

- 1) Remove FS-P (2, 41) and FS-S (58, 29) from the QHP terminal board.
- 2) Connect FS-P (2, 41) and FS-S (58, 29) to 41', 21', 29' and 58' of TS-88.
- 3) Connect the cable of T3-88 to the terminal board of T3-88' by matching colors.
- 4) Connect T3-88' to the QHP terminal board by matching numbers.
- 5) Connect the air tube (A1) to the air tube of the QHP with a union tee.

(4) Connecting of controller (T3-82 QHP-772)

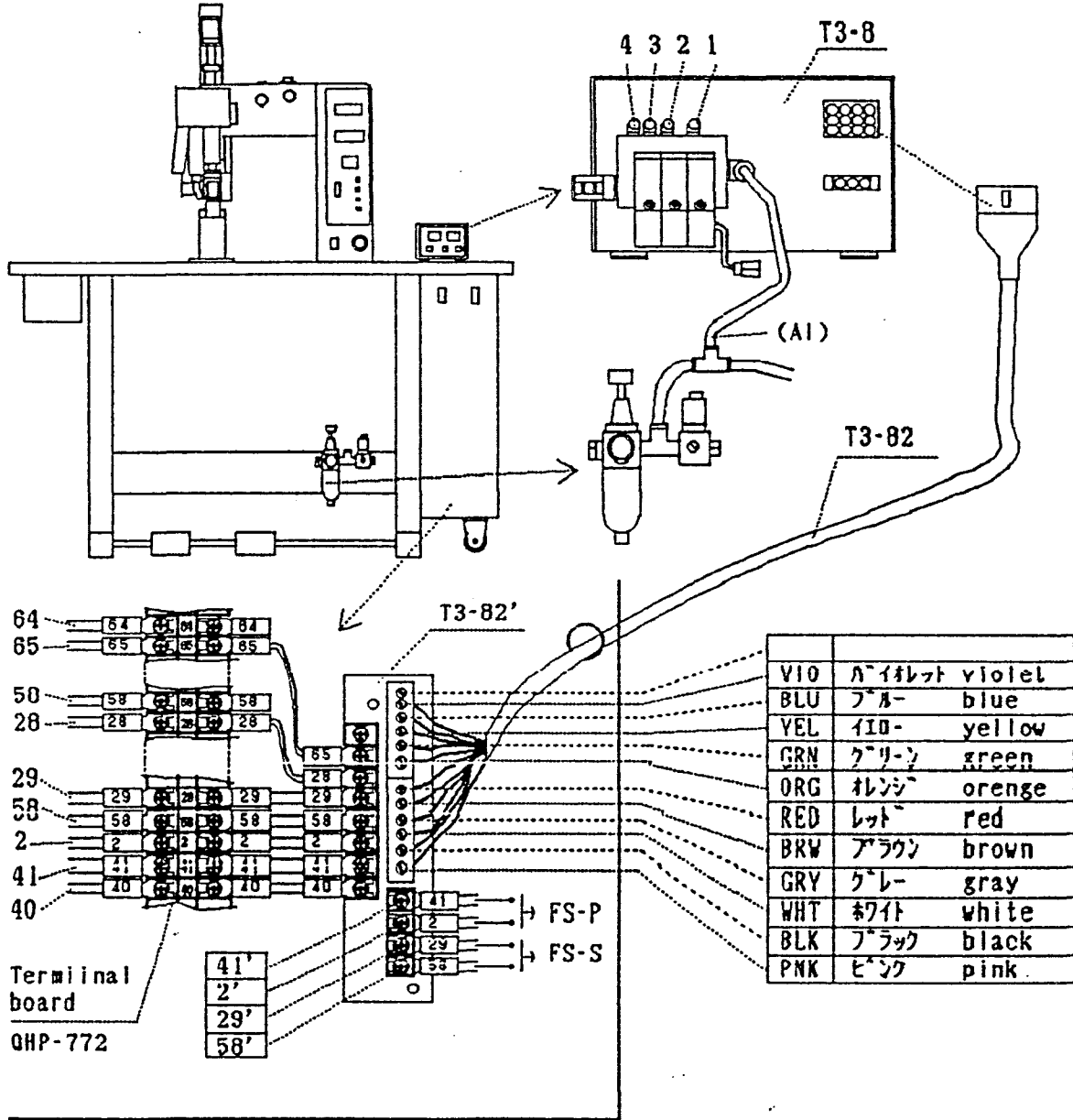

- 1) Remove FS-P (2,41) and FS-S (58,29) from the QHP terminal board.
- 2) Connect FS-P (2,41) and FS-S (58,29) to 41', 21', 29' and 58' of TS-82'.
- 3) Connect the cable of the T3-82 to the terminal board of T3-82' by matching colors.
- 4) Connect T3-82' to the QHP terminal board by matching numbers.
- 5) Connect the air tube (A1) to the air tube of the QHP with a union tee.

(5) Mounting of cutter (T3-0)

1: Remove the tape guide (A). [Fig. 1]

2: Fasten the cutter with 2 set screws (M4 x 8 truss (B)). [Fig. 2]

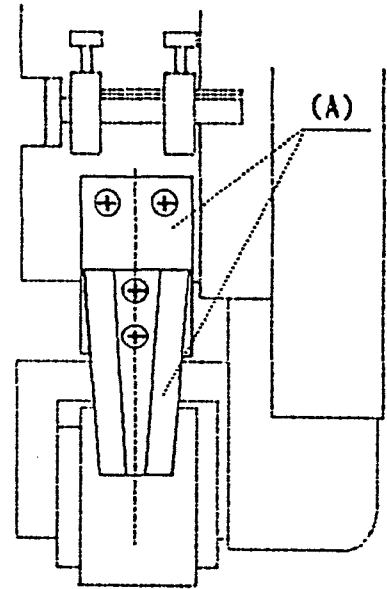

(6) Connecting of air tube and connector

[Fig. 1]

[Fig. 2]

1: Fit the air tube of No. (1) to (4) to the cutter coupling by matching numbers.

2: Connect the connector (M0).

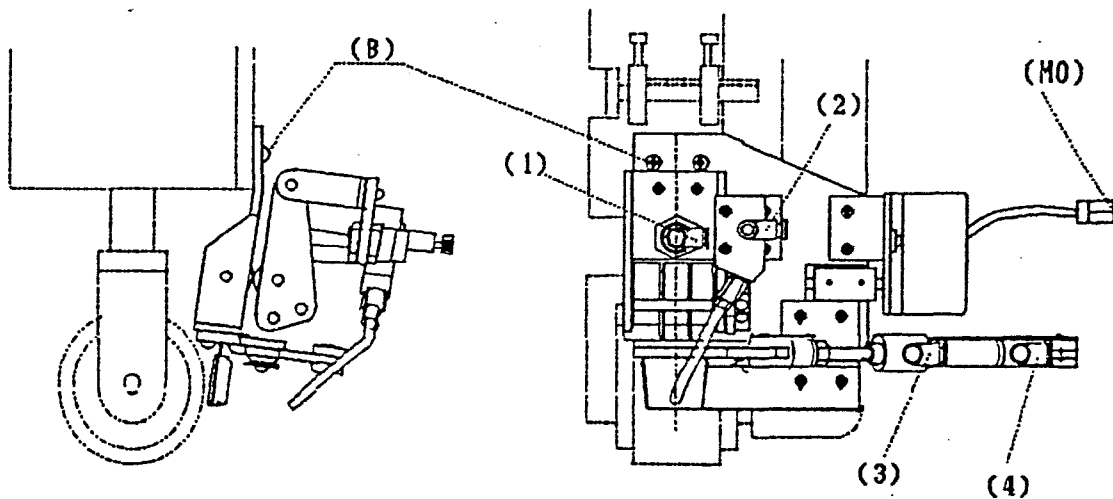

[Fig. 2]

(7) How to operate the tape cutter

1: Operation panel

- (PW) Cutter control power switch
- (TC) Manual tape cutting switch
- (CR) Tape clamp release switch
- (TF) Tape pay-out rate setting switch after tape cutting
- (SE) QHP automatic feed rate setting switch after tape cutting

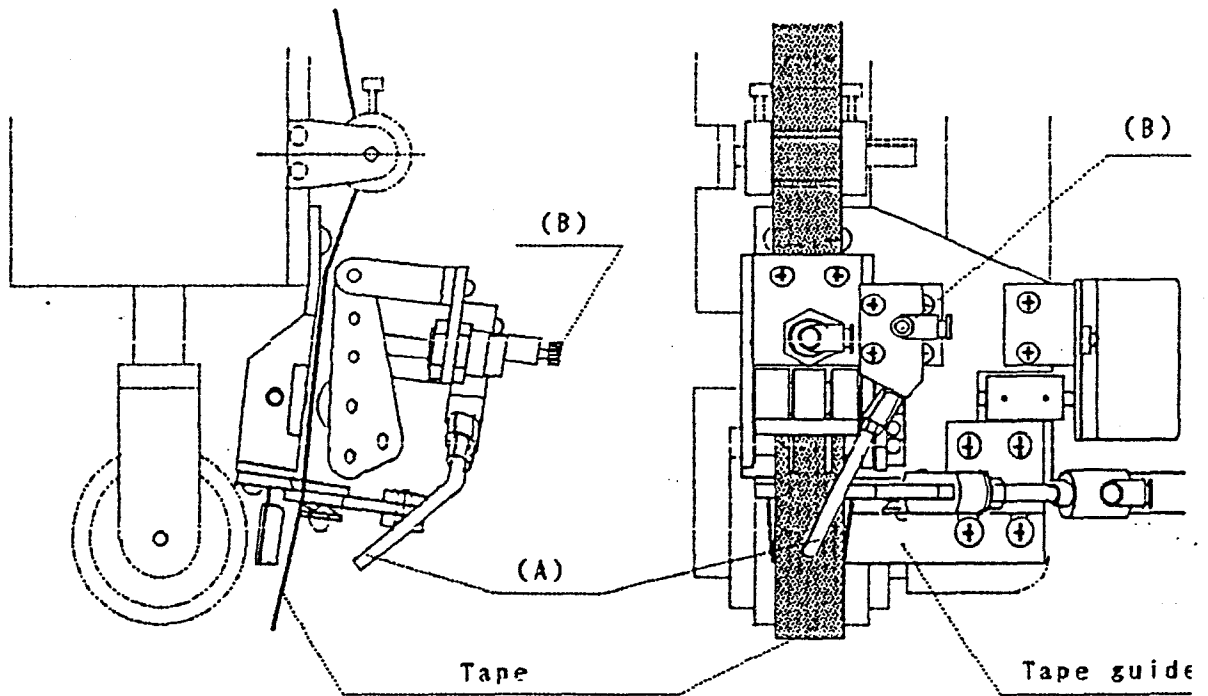
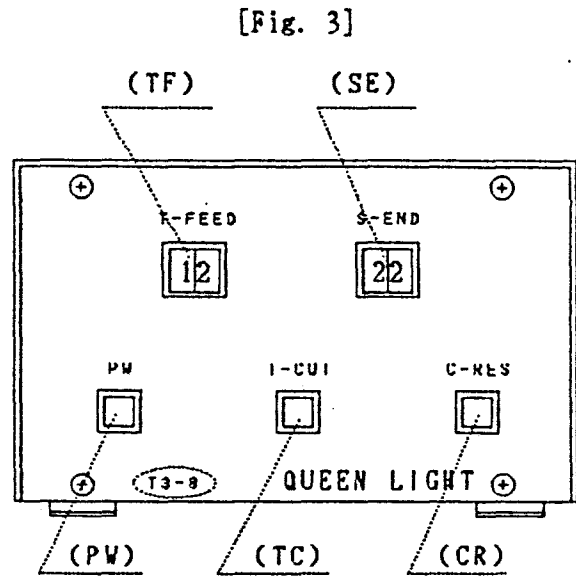

[Fig. 4]

(A) Air blow out port

(B) Air blow out rate adjust knob (for prevention of tape zig-zag moving).

: Air blows out from the air blow out port (A) at time of tape pay-out and lowering of the upper roller. Adjust the blow out rate so that zig-zagging of the tape is prevented.

## 2: Operation

(QHP power ON and upper roller in raised position)

- 1) Set the tape onto the tape cutter. (Fig. 4)
- 2) Push the power switch (PW). (Power ON Fig. 3)
- 3) Push the manual tape cutting switch (TC).  
[Air blows out from the air blow out port (A) simultaneously with pay-out of the set rate after tape cutting. The pay-out rate is set with (TF) and the blow out rate is adjusted with the knob (B). Fig. 4 & 5]
- 4) Set the material and step on the pedal (FS-P)  
[Air blows out from the air blow out port (A) after the upper roller drops down. The air blow out rate is adjusted with the knob (B) Fig. 4 & 5]
- 5) Step on the pedal (FS-S).  
[QHP starts Fig. 5]
- 6) Tape cutting consists of the following methods.
  - 1: Step on the pedal (FS-P while stepping on the pedal (FS-S).
    - ☆ The tape is cut and tape feeding takes place according to the set feed rate followed with automatic stopping, upper roller rise and tape pay-out. This sequence is repeated.
    - : Set the feed rate with the feed rate setting switch [Fig. 3 (SE)].
    - : The tape pay-out rate is set with the tape pay-out setting switch [Fig. 3 (TF)].
  - 2: Push the manual tape cutting switch [Fig. 3 (TC)].
    - ☆ Will not stop automatically, therefore, release the pedal (FS-S).
    - ☆ The upper roller does not automatically rise. Stop on the pedal (FS-P) by which the upper roller shall rise and tape pay-out will take place.
    - : The tape pay-out rate is set with the tape pay-out rate setting switch [Fig. 3 (TF)].

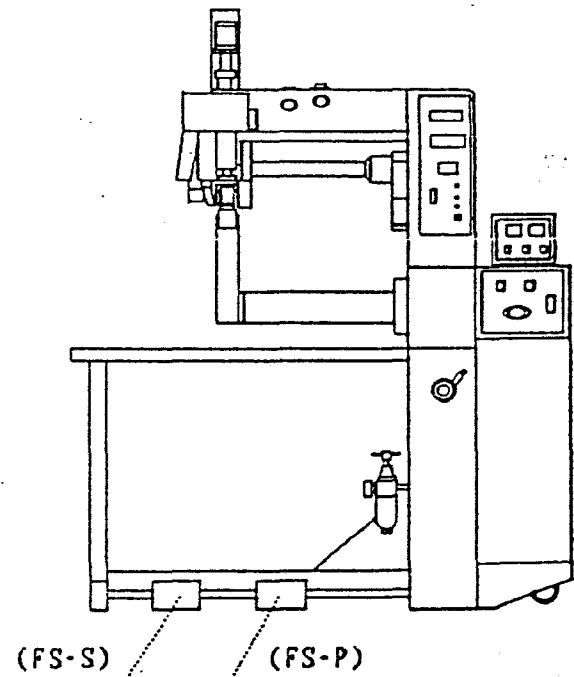







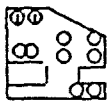
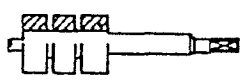

[Fig. 5]

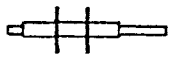
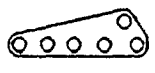
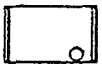
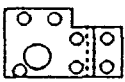
# PARTS LIST

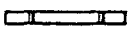

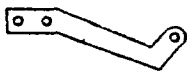

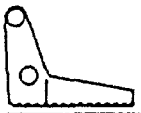
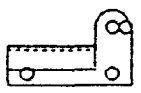
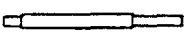

## QHP-T3 TAPE CUTTER

OK 10/194 cutter knife set #257.00

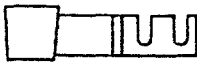
Code	Name	Schematic Drawing	Q'ty	Remarks
<u>RK 181</u>	Cutter Base(Substrate)		1	
<u>RK 182</u>	Lower Roller		1	
<u>RK 183</u>	Roller		1	
<u>RK 184</u>	Roller 2		1	
<u>RK 185</u>	Roller Plate		2	
<u>RK 186</u>	Roller Midele Plate		1	
<u>RK 187</u>	Presser Cylinder Base		1	
<u>RK 188</u>	Upper Roller Lever Base		1	
<u>RK 189</u>	Pin 5X39.5		1	
<u>RK 190</u>	Coupling 5		1	
<u>RK 191</u>	Knife Cylinder Base		1	
<u>RK 192</u>	Moter Base		1	
<u>RK 193</u>	Cutter Knife		1	
<u>RK 194</u>	Cutter Knife A (Fixed Knife)		1	
<u>RK 195</u>	Center Pin		1	

# PARTS LIST

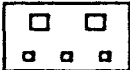
## QHP-T3 TAPE CUTTER

Code	Name	Schematic Drawing	Q'ty	Remarks
<u>RK 196</u>	Guide Fastening Plate		1	
<u>RK 197-1</u>	Guide		1	for 20mm tape
<u>RK 198</u>	Nozzle Base		1	
<u>RK 212</u>	Air Nozzle		1	
<u>RK 213</u>	Lower Roller Groove Wire		2	
<u>W 396</u>	Collar 4X6-6		1	for cutter knife shaft
<u>RRK201</u>	Control Panel		1	
<u>RK202</u>	Control Box		1	
<u>RK203</u>	Control Cover		1	
<u>4 T 8</u>	4 X 8 Truss		2	Cutter mounting screw

# PARTS LIST

## QHP-T3 TAPE CUTTER

3

Code	Name	Schematic Drawing	Q'ty	Remarks
Metal	80F-0404 (Oil-less)		3	for RK182 1 for RK188 2
Metal	80F-0303 (Oil-less)		4	for RK184 2 for RK195 2
Cylinder	PDA10×20-7P-Y (Koganei)		1	for knife
Cylinder	NSA10×5N ((Koganei)		1	for roller pressing
Speed Controller	SC4-M5B ((Koganei)		1	for air blow out
Coupling	SL4-M5 (Koganei)		3	for cylinder
Coupling	FCL6-M5 (CKD)		1	for manifold 6mm
Coupling	FCL4-M5 (CKD)		4	for manifold 4mm
Muffler	KM-11 (PT1/8) (Koganei)		1	
Manifold with Solenoid Valve	040M3A (Koganei)	Solenoid Valve DC24V A040E1 2 pcs A040-4E1 1 pce	1 組	Mounting Position 1:A040E1 2:A040E1 3:A040-4E1
Union Tee	UT6 (Koganei)		1	for 6mm tube
Gear	S508208+0303 (KG)		1	for RK184
Gear	S50824B+0303 (KG)		1	for RK195
Gear	S508308+0303 (KG)		1	for RK183
E-ring	E3		2	for RK189

# PARTS LIST

## QHP-T3 TAPE CUTTER

4

Code	Name	Schematic Drawing	Q'ty	Remarks
Spring H05-09	(Sanesu)		1	Spring fot RK186 pu;;
Wave Washer 6mm			1	for Cutter Knife
Motor J205-033	(CKD)		1	
Coupling 1A 4mm			1	for RK212 fastening
Soft Nylon Tube 4 x 2		NO.1 1510mm NO.2 1490mm NO.3 1420mm NO.4 1370mm	Each 1	
Soft Nylon Tube 6 x 4		1200mm	1	
P.C. Board T3-1-8	(O.L.)		1	for T3-8
Panel Substrate T3-PL1	(O.L.)		1	
Transformer E-7003	(O.L., Fujino)		1	100, 110, 120/9V-0-9V 0.5A
Connector 2P (AMP)		1-480319-0 Male 1-480318-0 Female	Each 2	for Motor
Connector 3P (AMP)		1-480305-0 Female	1	
Connector 12P (MOLEX)		1360P Male 1360R Female	Each 1	